

MAGNETIC LIQUID-LEVEL GAGES
Installation, Operation and Maintenance Instructions

1.0 Magnetic Level Gages

- 1.1.0. Description3**
 - 1.1.1 Introduction
 - 1.1.2 Components
 - 1.1.3 Chamber Material
 - 1.1.4 Internal Float
 - 1.1.5 Float Submergence
 - 1.1.6 Gage ratings
 - 1.1.7 Hydrostatic Testing
- 1.2.0 Level Indication4**
 - 1.2.1 Introduction
 - 1.2.2 Single Indication (ST)
 - 1.2.3 Single Indication - Reference Guide
 - 1.2.4 Flag Indication (WF)
 - 1.2.5 Flag Indication - Color Reference
 - 1.2.6 Flag Indication - Retrofit
- 1.3.0 Installation and Inspection5**
 - 1.3.1 Inspection
 - 1.3.2 Chamber Orientation
 - 1.3.3 Connection Valves
 - 1.3.4 Float Orientation
 - 1.3.5 Chamber Gaskets
 - 1.3.6 Flanges and Connections
 - 1.3.7 Interface Applications
- 1.4.0 Operation5**
 - 1.4.1 Introduction
 - 1.4.2 Procedures
- 1.5.0 Removal from Service6**
 - 1.5.1 Introduction
 - 1.5.2 Procedures
- 1.6.0 Maintenance7**
 - 1.6.1 Introduction
 - 1.6.2 Procedures
- 1.7.0 Troubleshooting7**
 - 1.7.1 Introduction
 - 1.7.2 Float & Indicator Detachment
 - 1.7.3 Differential Level
 - 1.7.4 Defective Indicator
 - 1.7.5 Switch Malfunctioning
 - 1.7.6 Transmitter Malfunctioning
- 1.8.0 Parts List8**
 - 1.8.1 Introduction
 - 1.8.2 Chamber
 - 1.8.3 Indicator & Scale Assembly
- 1.9.0 Warranty9**
 - 1.9.1 Introduction
 - 1.9.2 Conditions
 - 1.9.3 Provisions
- 1.10.0 Terms and Conditions of Sale9**
 - 1.10.1. Introduction
 - 1.10.2 Terms
 - 1.10.3 Shipment
 - 1.10.4 Restocking
 - 1.10.5 Cancellation

2.0 Pneumatic Level Control

2.1.0 Non Bleed, Block & Bleed Switches : MGS-100	10
2.1.1 Introduction	
2.1.2 Operating Specifications	
2.1.3 Installation Procedures	
2.1.4 Operation & Maintenance	
2.2.0 Pneumatic Level Controller - LCP	11
2.2.1 Introduction	
2.2.2 Operation	

3.0 Electronic Level Control

3.1.0 Reed Switch Transmitters: MGT-2000	12
3.1.1 Introduction	
3.1.2 MGT-2000 Sensor	
3.1.3 MGT-2000 Transmitter	
3.1.4 Installation	
3.1.5 MGT-2000 Specifications - Sensor	
3.1.6 MGT-2000 Specifications - Transmitter	
3.1.7 MGT-2000 Specifications - Power Requirements	
3.1.8 MGT-2000 Calibration - Transmitter	
3.1.9 MGT-2000 Calibration - Procedure	
3.1.10 Optional Display	
3.1.11 Display Procedure	
3.2.0 Magnetostrictive Transmitters: MGT-5000	15
3.2.1. Introduction	
3.2.2 Performance	
3.2.3 Adjustments	
3.2.4 Approvals	
3.2.5 Availability	
3.2.6 MGT-5000 Specifications	
3.3.0 Electric Switches: MGS200EX/MGS200EX2	17
3.3.1. Introduction	
3.3.2 Specifications	
3.3.3 Mounting	
3.3.4 Operation	
3.3.5 Electrical Wiring - Rising Level	
3.3.6 Electrical Wiring - Falling Level	
3.4.0 Electric Switches: MGS500EX/MGS500EX2	18
3.4.1. Introduction	
3.4.2 Specifications	
3.4.3 Mounting	
3.4.4 Operation	
3.4.5 Electrical Wiring - Rising Level	
3.4.6 Electrical Wiring - Falling Level	
3.5.0 Electric Switches: MGS700EX (/2), MGS-900EX(/2)	19
3.5.1 Introduction	
3.5.2 Specifications	
3.5.3 Mounting	
3.5.4 Operation	
3.5.5 Electrical Wiring - Rising Level	
3.5.6 Electrical Wiring - Falling Level	

1.0.0 MAGNETIC LEVEL GAGES

1.1 Description

1.1.1 INTRODUCTION

JOGLER'S magnetic level gages (MagGages™) are indirect reading liquid level indicators. Gages are manufactured to meet exact specifications of the process media such as operating pressure, temperature, specific gravity, etc. The magnetic level gages utilize non-magnetic 2.00-inch, schedule 40 chambers (standard) manufactured to specified length, with process connections that match those of the vessel or tank. For some high pressure or extreme low gravity applications, larger chambers are available. The process connections may be:

- Side mounted, threaded, flanged or socket welded
- Top and bottom flanged mounted
- Tank top mounted
- Combination

A variety of mounting styles is available to suit any vessel or piping requirements. Refer to the drawing depicting magnetic level gage mounting configurations.

1.1.2 COMPONENTS

The gage chamber contains a magnetic float and an external level indicator attached to the outside of the gage chamber. External indicators consist of either a single yellow or wide-flag model. The magnetic float maintains a magnetic field with the external level indicator. As the level of the process medium fluctuates within the tank and gage chamber, the float reacts accordingly, and the indicator records the level of the fluid within the chamber.

1.1.3 CHAMBER MATERIAL

Standard chamber materials are 316/304 stainless steel however any non-magnetic material may be used. Other chamber materials that are available include CPVC, Kynar, Hastelloy, Alloy 20, Zirconium and Monel. Carbon steel connections are available.

1.1.4. INTERNAL FLOAT

A magnetized float, contained inside the gage chamber, is designed for the exact process conditions. For this reason, floats are not interchangeable unless the process conditions and gage chambers are identical. The float moves freely inside the chamber reacting to fluctuating level changes within the adjoining vessel.

1.1.5 FLOAT SUBMERGENCE

Under normal operating conditions, the float is submerged about 80% or more in the process fluid. It is important to note, however, that the position of the float in the media will vary with different process conditions. Float magnets are located in the upper portion of the float.

1.1.6 GAGE RATINGS

Magnetic level gages can be designed for operating conditions from full vacuum service up to 5000 PSIG, 1100° F, and a minimum specific gravity of 0.20. All magnetic gages with alloy chambers will have full ANSI ratings based on flange classifications. Gages with CPVC, Kynar (PVDF) or fiberglass chamber flanges are rated to 150 PSIG maximum.

1.1.7 HYDROSTATIC TESTING

Gage chambers are hydrostatically tested to 150% of indicated gage rating without floats installed. Floats are tested individually. Gages can be field hydrostatically tested after installation at the operator's discretion. **CAUTION: DO NOT CONDUCT HYDROSTATIC TESTING OF THE MAGNETIC GAGE CHAMBER ATTACHED TO A PROCESS VESSEL WITH THE FLOAT INSTALLED. IF A GAGE IS FIELD TESTED WITH THE FLOAT INSTALLED, THE FLOAT MAY IMplode AND THE GAGE CHAMBER MAY BE DAMAGED. THIS PROCEDURE WILL VOID THE WARRANTY.**

1.2 Level Indication

1.2.1 INTRODUCTION

There are two types of external level indication options offered by JOGLER for magnetic level gages. The single tracker indicator (ST) is recommended for stagnant storage level applications with little or no level fluctuations. The wide flag indicator (WF) is recommended for turbulent or high vibration level conditions.

1.2.2 SINGLE TRACKER INDICATORS (ST or SST)

The single tracker assembly used for indicating level consists of a 1.40 inch wide rectangular yellow magnetic tracker sealed in a channel with a 304 stainless steel calibration scale marked in feet and inches, total inches or in centimeters. The indicator is mounted parallel and immediately adjacent to the gage chamber to allow maximum magnetic coupling between the float and the tracker within the indicator channel. The channel is sealed to prevent dirt and moisture accumulation. A red bumper is positioned at the bottom of the channel to cushion the impact of the tracker against the glass cover. Although the yellow tracker provides maximum visibility even at nighttime, retrofit kits for illuminating gages are available. The standard single tracker is designated ST. The single tracker with a 316 SS enclosure is designated SST. Maximum operating temperature is 400° F.

1.2.3 SINGLE TRACKER INDICATORS - REFERENCE GUIDE

A black reference guide in the center of the yellow tracker allows the operator to match the graduated scale with the level of the process fluid. When the indicator is properly oriented, the red internal bumper will be located at the bottom of the channel. A nameplate at the lower end of the scale provides zero level indication. If the yellow tracker is decoupled from the internal float's magnetic field, the tracker will descend below the zero point on the scale. Thus, when the vessel is empty, the level gage will read zero and the yellow tracker will remain visible. To prevent the float from losing magnetic coupling with the tracker, a spring is mounted inside the top and bottom of the gage chamber. This cushions the impact of the float against the chamber ends when the vessel is completely full or empty. The float and the tracker are magnetically coupled when the tracker remains visible. If the magnetic coupling is lost between the float and tracker, use a hand magnet to attract the tracker until it is contained within the float's magnetic field. Refer to the Troubleshooting portion of the manual, Section, 2.7.2.

1.2.4 WIDE FLAG INDICATORS (WF or SWF)

JOGLER offers a continuous wide flag indicator as an option to the single yellow tracker indicator. Wide flag indicators are industrial grade level indicators that consist of a series of one-piece ceramic flags, black on one side, yellow on the other. As the magnetic float reacts to level fluctuations, each ceramic flag rotates 180 degrees to reveal the opposite color.

JOGLER ceramic flags are housed in a sealed housing with a recessed glass window and rotate on a stainless steel shaft, which prevents the flags from sticking. Housing materials are either anodized aluminum (WF) or 316 stainless steel (SWF). The unique design prevents all flags from rotating in excess of 180 degrees and each flag is magnetically coupled, above and below. Wide flag indicators are recommended where surging or turbulent level conditions exist. Each flag indicator is 1.40 inches wide and is the most visible flag style indicator available. Maximum operating temperature is 1100° F.

1.2.5 WIDE FLAG INDICATION - COLOR REFERENCE

The standard color combinations for flag indicators are bright yellow and black. Yellow represents liquid column; black represents vapor space. Optional colors are available. Please consult the factory for other color combinations.

1.2.6 INDICATOR RETROFIT

When flag style indicators are purchased with a JOGLER magnetic level gage, no installation is necessary. If the indicator is removed or a retrofit kit is purchased for a gage already in service, however, the following steps should be noted:

- The mounting clamps connecting the flag assembly to the gage chamber are adjustable to most manufacturers' standard, (i.e. 1.50 inch to 3.00-inch pipe). If the gage is in service and there is liquid in the tank, only the flags adjacent to the float will rotate to yellow when the indicator assembly is clamped on.
- Run a magnet along the window of the indicator from zero to where yellow is showing as noted, or,
- Drain the gage to zero on the indicator, then fill again. As the float rises, the level indicator will react accordingly and will be reset properly.

1.3 Installation

1.3.1 INSPECTION

All magnetic level indicators are securely packed in crates to provide maximum protection of the equipment during shipment. It is important to unpack and inspect each gage upon receipt to insure the indicator and chamber were not damaged in shipment. If you should find damaged parts, contact JOGLER immediately. All JOGLER magnetic gages are fully insured against damage or loss unless specified by the customer otherwise. Claims must be filed within 15 days from the date of receipt of shipment.

1.3.2 CHAMBER ORIENTATION

The magnetic float is packaged separately for shipment, which should be removed before installation. The float chamber should always be leveled vertically. If it is not leveled correctly, the indicator may produce inaccurate readings.

1.3.3 CONNECTION VALVES

Valves should be installed between the process vessel and level gage to allow for isolation, draining, and cleaning purposes. (See section 1.6.2. on Maintenance for more details on cleaning and maintenance procedures). Standard block valves can be ordered with the gage or separately from JOGLER. Ball check valves are not necessary for magnetic level gages. If certain valve specifications are required, please advise JOGLER accordingly.

1.3.4 FLOAT ORIENTATION

The internal magnetic float has a preferred orientation vertically which is inscribed at the top of the float. Install the float properly by taking note of the correct orientation through the chamber flange connection. If the float is installed into the chamber inverted, it will not couple with the external indicator correctly, resulting in improper level indication. Floats that are installed in gages with inverted chamber construction will contain a loop at the top of the float for installation and removal purposes. INTERNAL FLOATS SHOULD BE INSTALLED AFTER ANY HYDROSTATIC FIELD TESTS OF THE CHAMBER AND CONNECTING VESSEL ARE COMPLETE.

1.3.5 CHAMBER GASKETS

Standard magnetic level gages are supplied with 0.125-inch composition gaskets. If this type of gasket is not compatible with the process media, appropriate gaskets should be used in replacement of those shipped with the gage. Please consult the factory.

1.3.6 FLANGES AND CONNECTIONS

Process connections and vent/drain flanges are designed to meet each customer's specifications. All flange bolt holes straddle the centerline unless otherwise specified. Both male and female threaded connections and socket weld connections are available.

1.3.7 INTERFACE APPLICATIONS

Magnetic gages can be used to identify fluid interfaces only if the proper specific gravity have been identified at the maximum operating conditions. The float can be designed to float in one media while sinking in the other. Immiscible oil over water level is an example. Care should be exercised, however, when using magnetic gages in interface applications because rag layers (or emulsions) may exist which are difficult to identify.

Gages with two floats and two single indicators on one chamber for an interface and total level identification have limited performance. The two floats may collide causing incorrect level readings, especially if the lighter liquid phase is thin or the vessel is short. Chambers can be manufactured with multiple connections for maximum process influx. The proper method is to install one gage per process phase.

1.4 Operation

1.4.1 INTRODUCTION

It is important that all instructions pertaining to entering magnetic level gages into service be read thoroughly first before commencing with service operations. Failure to do so may void the warranty by subjecting the gage to a potential safety hazard.

1.4.2 PROCEDURES

1. Check that the operating conditions, (temperature, pressure and specific gravity) are within the maximum rating of the gage. Each gage has a permanent nameplate indicating process specifications, serial number, tag number, etc. It is criti-

cally important to check that the specific gravity of the process media is specified at the maximum operating conditions.

2. The gage chamber should be leveled vertically, empty, blocked in and isolated. Check to see that all drain and vent plugs are in place. Close all vent and drain valves if plugs are not used.
3. STANDARD GAGES. Install the float by removing the bottom drain flange located at the base of the gage. The float is marked TOP to insure proper orientation. A spring is attached to the inside of the drain flange to cushion the float when the vessel is empty. Reinstall the bottom drain blind flange with a new flange gasket after the float is in place.

INVERTED GAGES. Remove the top vent blind flange from the gage chamber. The float contains a float loop; install the float by inserting a string through the float loop and lower the float into position slowly. Remove the string from the float and chamber after the float is resting on the bottom of the gage. If the float does not contain a loop, fill the ambient chamber with water. Insert the float and allow the chamber to drain slowly. An auxiliary magnet may be required to recouple the external indicator to the internal float.

4. Reinstall the blind flange with a new gasket. The gage chamber should be isolated with no opening to atmosphere. Check to see that all drain and vent plugs are securely in place and that any vent and drain connections are closed.
5. When the gage is mounted and ready for placement into service, PARTIALLY OPEN THE TOP PROCESS CONNECTION VALVE FIRST and very slowly to allow initial pressure and temperature equalization between the vessel and the level gage. This allows the process conditions of the vessel to slowly equalize with the gage and reach operating conditions at an even and reasonable rate.

CAUTION. DO NOT OPEN THE BOTTOM PROCESS CONNECTION VALVE FIRST. IF THE BOTTOM VALVE IS OPENED FIRST WITH THE TOP VALVE CLOSED AND THE VESSEL IS UNDER PRESSURE, THE INTERNAL FLOAT WILL RISE INSTANTLY AND LODGE ITSELF IN THE TOP OF THE CHAMBER ,CAUSING SEVERE DAMAGE TO THE FLOAT AND CHAMBER.

6. After the float chamber has reached process conditions, continue to open the TOP process connection valve slowly, allowing any liquid or condensate to enter the gage slowly. This procedure is critically important for high pressure and temperature applications. The float and indicator may react or rise to condensate accumulation migrating through the top valve with the bottom valve closed.
7. When the gage chamber has attained normal operating conditions, open the BOTTOM process valve connection slowly. This will allow proper fluid entry into the gage chamber under normal operating conditions. The level indicator should rise vertically, thus rendering a fluid level. Flag indication will result in black to yellow rotation of the flags as the fluid rises. At this point, installation should be complete. Allow at least 30 minutes for both top and bottom valve procedures.

NOTE: Under elevated operating conditions, the indicator may record a significant level from condensate influx through the top valve before the bottom valve is opened. If this is the condition, it is possible the indicator (and float) may readjust and fall slightly from the effects of final process equalization after the bottom valve is completely opened.

1.5 Removal from Service

1.5.1 INTRODUCTION

To remove the gage from service, the next steps should be followed to prevent danger to personnel and damage to the gage when the vessel is pressurized.

1.5.2 PROCEDURES

1. Close the bottom process connection valve first to prevent further process influx to the gage.
2. Completely close the top process connection valve to isolate the gage from the process conditions.
3. Attach proper vapor collection equipment to the gage vent connection if required.
4. Open the vent valve slowly to relieve gage pressure and allow ambient air influx.
5. Attach the proper liquid collection equipment to the drain connection if required.

6. Open the drain valve slowly to remove remaining gage liquid.

CAUTION: NEVER USE THE VENT OR DRAIN ON A GAGE AS A PRESSURE RELIEF MECHANISM FOR THE PROCESS SYSTEM. DOING SO MY PERMANENTLY DAMAGE PARTS OF THE GAGE AS WELL AS INDUCING AS CREATING A SAFETY HAZARD.

1.6 Maintenance

1.6.1 INTRODUCTION

JOGLER magnetic level gages contain a standard 0.50 inch vent and drain plug in the top and bottom of the gage chamber to allow cleaning and removal of the process fluid if required. Socket weld vent and drain valve connections are available. Some gages are connected to a solvent or steam line that allows empty gages without floats to be decontaminated or blown down periodically without removing the gage from the vessel location. JOGLER magnetic gages should be maintained and inspected on at least an annual basis, or more frequently depending on the process system.

1.6.2 PROCEDURES

1. Block in the gage chamber with the process connection valves or wait until the vessel is empty and out of service.
2. Close the bottom valve first and the top valve second.
3. Open the vent valve slowly or remove vent plug carefully to depressurize the gage especially if the gage has been under pressure.
4. Open the drain valve slowly or remove the drain plug carefully to allow any remaining fluid to drain from the chamber.
5. When all of the gage fluid has been drained, carefully remove the drain flange and float from the gage chamber. Be sure to examine the float for excessive wear and clean as required.
6. Clean the inside wall of the chamber with a "bottle brush" or similar scrubbing tool. Some processes may require the use of a suitable solvent for cleaning.
7. After cleaning the chamber, replace the float and drain flange. A new flange gasket should be installed. Use gaskets compatible with the process media if replaced. Note the orientation of the float before installation.
8. Check the stainless steel pipe clamps to insure they are tight and adjust the scale channel. Correctly match the zero point to process connection elevations.
9. If necessary, use a permanent magnet to attract the yellow indicator until it is coupled to the float inside the chamber.

1.7 Troubleshooting

1.7.1 INTRODUCTION

JOGLER magnetic level gages are simple to install and operate. The following troubleshooting tips may be of assistance during installation and startup. Complete reading of this is required.

1.7.2 FLOAT AND INDICATOR DETACHMENT

- If detachment is a frequent problem, it could be caused by several factors, most of them resulting from improper installation of the gage, particularly the float.
- Check to ensure that the scale and channel assembly is fastened tight against the gage chamber so that magnetic coupling is maintained from top to bottom of the indicator.
- Check to ensure the internal magnetic float within the chamber is right side up. If the float was installed inverted, the single yellow indicator will magnetically couple, but the actual process level will be higher than what the indicator records. All floats are clearly marked TOP. Floats designed for inverted gages will have a loop welded at the top of the float for installation and removal purposes.
- If the float springs mounted in the top and bottom of the gage chamber have been removed, the float could rise past the top of the indicator and lose magnetic coupling with the indicator.

- If the process connection dimension has been miscalculated and the gage length is too long, do not attempt installation because it will warp the chamber. A warped chamber will inhibit float movement, possibly causing float and indicator detachment.

1.7.3 DIFFERENTIAL LEVEL

This can occur during startup and is easily corrected. Under normal operating conditions, most floats are about 80% submerged in the process media. It is important to note that the position of the float in the fluid will vary with different process conditions. To attain a true level elevation, adjust the scale vertically to get an exact reading.

1.7.4 DEFECTIVE INDICATOR

If the glass indicator cover is cracked or broken, a replacement cover can be shipped within 24 hours after receipt of order. One advantage of the magnetic level gage is the indicator assembly can be serviced without removing the gage chamber from service. To replace the indicator cover, remove the four screws from cover plate at the top and bottom of the indicator channel. There are two red gaskets beneath each cover that require removal. Remove the two red seal strips and slide the glass plate cover out of the channel. Clean any debris or fragments. Replace the glass cover with the new glass plate by sliding into the channel again. Replace each red side and top gaskets with the top and bottom covers. If the gage is in excess of 6 feet in length, it may be easier to remove the indicator from the channel. Refer to gage serial number when ordering parts.

1.7.5 SWITCH MALFUNCTIONING

All level switches may be wired to trip on rising or falling level. After the switch is connected to the desired alarm function, it is necessary to set the switch. This is accomplished by passing the float either manually or by filling the gage chamber until it passes the highest switch. This will trip the switch to the desired setting so it will alarm properly with rising or falling level.

1.7.6 TRANSMITTER MALFUNCTIONING

If the total calibrated span of a MGT-200/MGT-5000 transmitter does not match with the level indicated on the chamber, the transmitter sensor may contain a defective reed switch. Please consult the factory for additional assistance.

1.8 Parts List

1.8.1 INTRODUCTION

When ordering spare parts for the MagGage series magnetic level gage, the following information will be required.

- Serial number of the gage or accessory item.
- Description of parts to be ordered.
- Model number of the parts to be ordered, if known.
- Original purchase order, if known.

1.8.2 CHAMBER PARTS

- Vent plug.
- Float chamber
- Chamber blind flange, spring, and gasket.
- Drain plug.
- Internal magnetic float.

1.8.3 INDICATOR AND SCALE ASSEMBLY PARTS

- Channel assembly
 - Anodized aluminum indicator track with single tracker or flag indication
 - Stainless-steel indicator track with single tracker or wide flag indication
- Top and bottom seals
- Calibration scale (total inches, feet and inches, centimeters)
- Chamber clamps
- Identification Tag.

1.9 Warranty

1.9.1 INTRODUCTION

All JOGLER products are warranted against defects in material and workmanship for one year (365 days) from the date of shipment. JOGLER will repair or replace those products that fail to perform as specified with the following exceptions. This warranty does not apply to glass breakage or any other liability other than materials and workmanship.

1.9.2 CONDITIONS

Products repaired or modified by persons that are unauthorized by JOGLER, INC.

Products subject to misuse, negligence or accidents

Products that are connected installed or otherwise used in such a way not in accordance with the manufacturer's instructions.

1.9.3 PROVISIONS

This warranty is in lieu of any other warranty expressed or implied by any party other than JOGLER. Repairs and/or replacements shall be at the sole discretion of JOGLER based on the terms and conditions.

1.10 Terms and Conditions of Sale

1.10.1 INTRODUCTION

All orders are to be entered through your local sales representative or to the following address:

JOGLER, INCORPORATED
9715 Derrington Road
Houston, Texas USA 77064
Telephone: 281-469-6969
Toll free: 800-223-8469
Fax: 281-469-0422
Email: jskinner@jogler.com

1.10.2 TERMS

The payment terms are Net 30 days to approved customers. Sales representatives may assume collection responsibility for new accounts at their discretion. Late charges will be added at the rate of 1.50% per month.

1.10.3 SHIPMENT

All shipments will be F.O.B. factory location, Houston, Texas, USA, via motor freight insured. Freight charges are normally prepaid and added to invoice unless specified otherwise.

1.10.4 RESTOCKING

Every magnetic level gage is designed and manufactured to exact customer specifications. As a result, there will be no restocking option after shipment is made.

1.10.5 CANCELLATION

Cancellation charges after order placement will be applied at the discretion of JOGLER, INC. and dependent upon production phase of the product and percent completed. Customer is responsible for all production charges and material costs in the event of an order cancellation.

2.0 PNEUMATIC LEVEL CONTROLS

2.1 Non-Bleed, Block and Bleed Switches (MGS-100)

2.1.1 INTRODUCTION

MGS-100 pneumatic switches are designed for use on JOGLER magnetic MagGage™ series gages only. The MGS-100 is a non-bleed, block and bleed pneumatic switch operates when the magnetic field of a JOGLER magnetic float passes by it, either on a rising or falling level condition. Since there no are direct interaction or connection between the switch and float, it is very important that all installation instructions be followed properly for the switch to function reliably. Please read all installation and operation instructions before beginning installation.

2.1.2 OPERATING SPECIFICATIONS

Medium:Filtered air or gas
Supply Pressure:Vacuum to 200 PSIG
Max. Temp:200° F (93° C)
Air Flow:29 SCFM @ 100 PSIG
Air Consumption:Zero SCFM

2.1.3 INSTALLATION

1. Loosen the included hose clamps completely and install them so they surround the gage chamber.
2. Reattach the clamp to itself, make 2 or 3 turns of the clamp's screw but do not reattach completely.
3. Insert the top "L" shaped bracket under the top hose clamp and tighten the clamp to the gage chamber. The top bracket is the bracket above the front label if the writing is right side up. Before tightening, you may adjust the height at which you would like the alarm to trigger. The trigger point is at the midpoint of the enclosure.
4. Since the switch should be securely fastened to the gage chamber by the top clamp, slide the bottom hose clamp over the bottom bracket and tighten the clamp to the gage chamber.
5. The alarm switch should be mounted so that it is level with the ground. If it is not level, loosen the hose clamps, adjust the switch's alignment, and when the switch is level, retighten the hose clamps. Improper alignment may cause the switch to malfunction.

CAUTION: THE SWITCH MUST ALSO BE FLUSH AND TIGHT AGAINST THE CHAMBER. FAILURE TO DO THIS RESULTS IN VIBRATION AND RATTLING OF THE SWITCH, WHICH MAY IN EXTREME CIRCUMSTANCES CAUSE THE SWITCH TO FAIL.

CAUTION: NO MATERIAL SHOULD BE PRESENT BETWEEN THE SWITCH HOUSING AND THE GAGE CHAMBER. ANY MATERIAL PRESENT CAN INTERFERE WITH THE MAGNETIC FIELD OF THE INTERNAL FLOAT AND PREVENT PROPER ACTIVATION OF THE SWITCH.

2.1.4 OPERATION AND MAINTENANCE

The pneumatic supply line must be connected to the connection labeled 1 or 2. The output to the alarm or other signaling device must be connected to the connection labeled PORT 3.

PORT 1 is the supply port that will activate the output when the float passes above the switch. It is to be used as a HIGH LEVEL indicator.

PORT 2 activates the output when the float passes below the switch. It is to be used as a LOW LEVEL indicator.

All input and output connections are 1/4-inch NPT connections.

The muffler must remain uncovered and clean for proper non-bleeding functioning of the switch. If covered, the interior of the switch may pressurize and explode.

Pneumatic connections must provide air or gas that is free of particulate matter or debris. Dirty supply gas may cause the valve inside to clog and lead the switch to failure.

2.2 Pneumatic Level Controller (LCP)

2.2.1 INTRODUCTION

The LCP Pneumatic Level Switch Controller provides supply and vent air control for two pneumatic switches used in a high and low point level application. The LCP is designed to be used with pneumatic switches on magnetic MagGage series gages only.

2.2.2 OPERATION

- As the float rises past the high pneumatic switch level, it will supply air to the port P4 of the controller.
- When port P4 has air supplied to it there will be a pneumatic signal out of port 2 of the controller. The pneumatic signal will continue until the float passes the low pneumatic switch.
- The low switch will supply a signal to port P2 on the controller therefore shutting the pneumatic signal off. The output signal will stay off until the float rises past the high pneumatic switch.
- The cycle will then repeat.
- To reverse the output on the controller, connect the high pneumatic switch to port P2, and the low pneumatic switch to P4 on the controller.

3.0 Electronic Level Controls

3.1 Reed Switch Level Transmitter (MGT-2000)

3.1.1 INTRODUCTION

The Reed Switch Level Transmitter (MGT-2000) is designed for magnetic MagGage series gages only and provides a continuous 4 to 20 milliamp liquid level signal for remote level indication or control. The transmitter comprises two components, the transmitter and sensor tube, which are mounted externally to the side of each magnetic level gage. The MGT transmitter is a non-intrusive device. Optional remote mounted digital displays are also available.

3.1.2 MGT-2000 SENSOR

The MGT sensor provides an electronic signal to the transmitter that is proportional to the liquid level indicated by the level indicator on the gage chamber. The sensor consists of a circuit board mounted within a stainless steel tube. The circuit board contains a chain of resistors and magnetically operated reed switches. The sensor length corresponds to the level span being measured which is normally equal to the connection length of the level gage. As the internal magnetic float responds to fluctuating level, the magnets within the float closes the nearest reed switch in the sensor tube. The total voltage drop across the resistance chain from the bottom of the sensor to the location of the closed reed switch is compared to the voltage drop across the entire reed switch chain. This ratio is sensed by the transmitter and becomes the indication of continuous liquid level.

3.1.3 MGT-2000 TRANSMITTER

The MGT transmitter provides a 4 - 20 mA electronic signal proportional to the level indicated by the external indicator mounted on the gage chamber. The transmitter consists of an electronic assembly mounted into an explosion proof and weatherproof enclosure. The transmitter is powered by 24 VDC (2 wire), 12 VDC (3 wire), or 110 VAC (4 wire) version, depending on the application. The transmitter supplies a constant current to the sensor's resistance chain. Each resistor in the resistor chain causes a voltage drop as the result of current flowing through it. As the internal float rises or falls with level, it is closing (rising level) or opening (falling level) reed switches, therefore changing the resistance in the sensor. The total of the resistors located between that end of the chain and closed switch results in output voltage. The transmitter converts this signal into a 4 - 20 mA output proportional to liquid level.

3.1.4 INSTALLATION

Please read all information pertaining to the MGT system before installation. The following steps should be taken if the transmitter is not factory installed.

CAUTION: FOR HIGH-TEMPERATURE APPLICATIONS, AN INSULATING STRIP IS PLACED BETWEEN THE SENSOR AND LEVEL GAGE CHAMBER.

1. Position the MGT against the chamber with the enclosure located at the top.
NOTE: The axis of the sensor tube should be parallel to the axis of the gage chamber.. Zero starts at 3 inches above the bottom of the sensor.
2. Secure the MGT against the gage chamber with stainless steel clamps and Z brackets.
3. Install the large pipe clamp around the chamber and the small clamp around the sensor tube.
4. Insert a Z bracket between the two clamps and tighten.
NOTE: There is a minimum of two sets required. Longer transmitters require additional clamps.

3.1.5 MGT-2000 SPECIFICATIONS - SENSOR

LengthUp to 20 feet
Resolution:0.50 inch (0.25 inch optional)
Enclosure:Stainless Steel
Operating Temp:Up to 500° F (260° C) process temperature.

3.1.6 MGT-2000 SPECIFICATIONS - TRANSMITTER

Output Limits:3.8 mA to 26 mA
Temperature Range:-20° to 180° F (-29° to 82° C).
Enclosure:Explosion Proof, Class 1, Division 1, Groups B, C, D, and E.

3.1.7 MGT-2000 SPECIFICATIONS - POWER REQUIREMENTS

- 2 Wire Loop Power24 VDC Nominal, 50 VDC Maximum.
- 3 Wire Low Power:8 VDC to 36 VDC @ 6 mA.
- 4 Wire AC Power:115 VAC Standard

3.1.8 MGT-2000 CALIBRATION - TRANSMITTER

Connect the transmitter as shown in the wiring diagram below. Calibration should be performed using the actual sensor. The Zero and Span adjustments are accessible on the front panel of the transmitter. The screwdriver blade used to adjust the potentiometer should not be more than 0.100 inch in width.

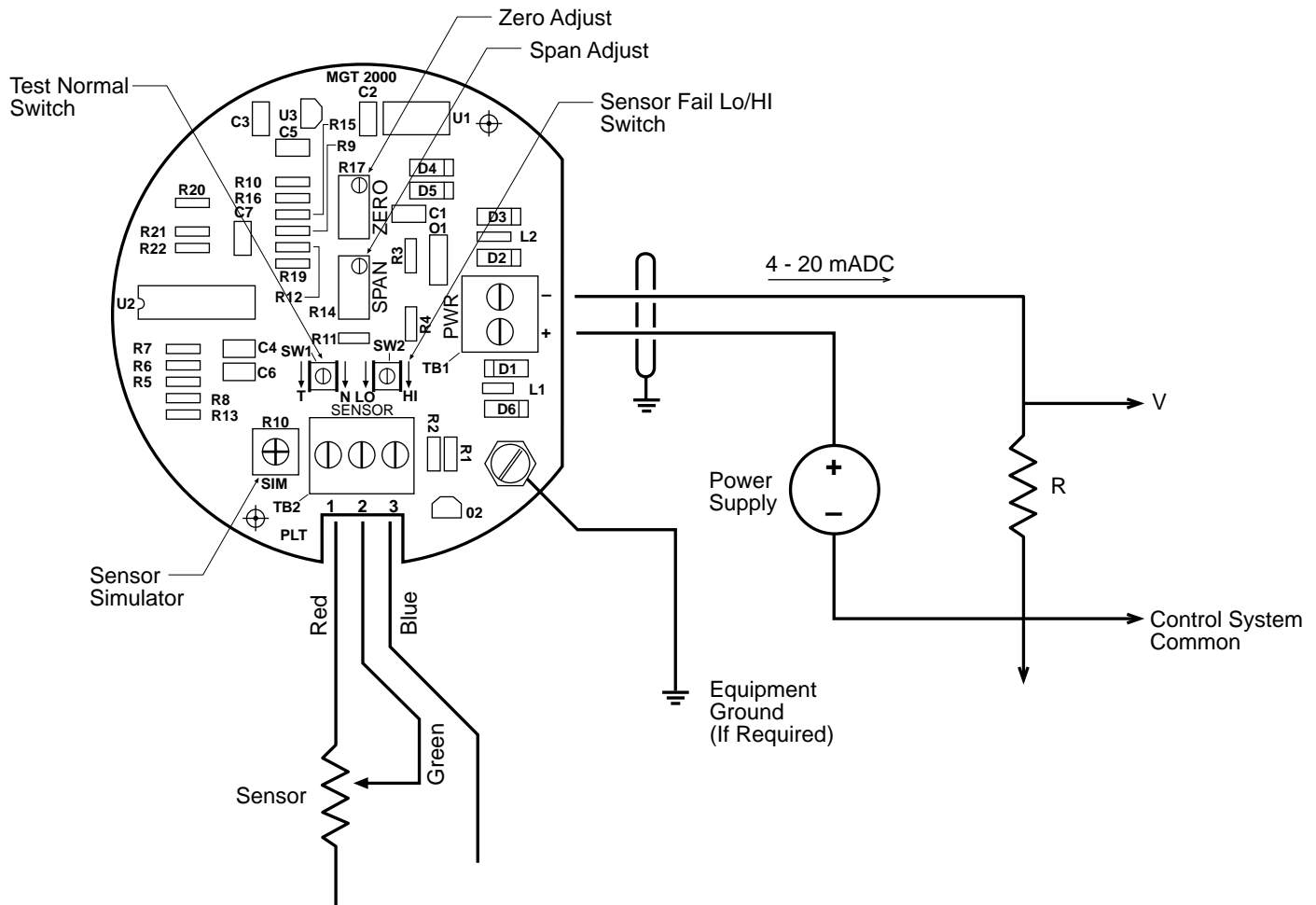

1. Diagram shows connections for transmitter mounted at top of sensor. Swap Red and Blue wires when transmitter is mounted at bottom of sensor.
2. Test/Normal Switch operation as follows: Turn switch fully counterclockwise for test position. Sensor Simulator control (R10) may then be used to simulate the sensor input. Turn switch fully clockwise for normal operation.
3. Sensor Fail Lo/Hi Switch operation as follows: Switch turned fully counterclockwise will cause transmitter to output less than 4 mA on loss of input from sensor. Switch turned fully clockwise causes transmitter to output greater than 20 mA on loss of input from sensor. Selection should be made prior to calibration.

3.1.9 MGT-2000 CALIBRATION - PROCEDURE

1. Set the float at minimum level which is the zero point of the transmitter span
2. Adjust the Zero (Z) pot until the display reads 4.00 mA DC.
3. Set the float to maximum level.
4. Adjust the Span (S) pot until the output reads 20.00 mA DC.
5. Repeat steps 1 through 4 until the readings converge. The transmitter is now calibrated.
6. Several mid-point values should be checked to verify the proper operation of the system.

3.1.10 OPTIONAL DISPLAY

If your MGT level transmitter has the display option, the display is calibrated separately from the transmitter. The calibration of the transmitter should be verified first, before proceeding with the calibration of the display (follow the above procedure). NOTE: The display option is factory configured for a specific customer specified range (0% - 100% is standard). The display Zero (DZ) and Span (DS) adjustments are trim adjustments only.

3.1.11 DISPLAY PROCEDURE

1. Set the float at minimum level (the Zero point of the transmitter span).
2. Adjust the Zero (DZ) pot of the display module for zero of the display range (0.0%).
3. Set the float to maximum level (the Span point of the transmitter).
4. Adjust the Span (DS) pot of the display module for the full scale reading (100%).
5. Repeat steps 1 through 4 until the reading converge. The display is now calibrated.

3.2 - Magnetostrictive Level Transmitter (MGT-5000)

3.2.1 INTRODUCTION

The MGT-5000 Magnetostrictive Level Transmitter is a loop-powered transmitter that provides a 4 to 20 milliamp output for remote verification of level. It is designed for magnetic MLG series gages only for routine, general-purpose level measurement and is easily integrated into existing process control systems. The transmitter can be installed on any level gage without interruption of the process system

3.2.2 PERFORMANCE

The MGT-5000 transmitter provides continuous measurement of process level with repeatability to 0.01% full scale and overall accuracy 0.10% of full scale. There are no moving parts thus promoting prolonged reliability. The transmitter requires no calibration or scheduled maintenance to stay within specifications. Density, temperature, and dielectric changes do not affect the transmitter ability to repeatedly track process level. Transmitter accuracy is dependent on the level fluctuations generated by the internal float.

3.2.3 ADJUSTMENTS

The MGT-5000 is completely sealed and never has to be opened to the environment. When attached to the gage chamber, the transmitter does not come in contact with the process (non-intrusive). The zero and span adjustments are performed using a hand magnet (supplied) to turn the two internal potentiometers.

1. Connect the HART communicator (model 275) to the HART terminals labeled HART on the front panel display of the MGT-5000 transmitter module.
2. Press the black and white I/O button on the HART terminal. The terminal will go into self test, then into main screen. If not connected properly, you will get a "No device found" message.
3. From main screen, press keypad key #1, "Device Setup".
4. From the Device Setup screen, press key #3, "Basic Setup".
5. Press key #3. You are now in Range Values screen.
6. To set LOW VALUE, select key #1. You are now in the PV LVR Key in the low value range (3 inches is shown. If 4 inches is desired, key in 4.)
7. To set HIGH VALUE, select key #2. You are now in the PV UVR Key in the high value range (e.g., if 60.5 inches is desired, key in 60.5). When the new desired high value is keyed in, press "Enter" (F4 Button). To write the changed value to memory, press "SEND" Key now. Next you will see two "Warning" screens that ask if you are sure. If your new high values are correct, press "OK" for both messages.
8. You are back in the Range Value screen. If the numbers for lower and upper are correct, press the "SEND" key. You will get a "Warning". Press "OK" again.
9. Setup is now complete

3.2.4 APPROVAL

- The MGT-5000 is Factory Mutual and CSA approved.
- Area classifications are Class 1, Division 1, Groups C, D, E, F, and G hazardous locations.

3.2.5 AVAILABILITY

- Standard lengths are available up to 20 feet. Longer lengths are available, please consult the factory.

3.2.6 MGT-5000 SPECIFICATIONS

Measured Variable:Single Level
Full Range:1 to 25 feet (standard)
Non-linearity:0.1% of full scale
Repeatability:0.01% of full scale
Input Voltage:10.5 to 36.1 VDC
Reverse Polarity:Series diodes
Approvals:Factory Mutual and CSA, Intrinsic Safety Approval
Area Classification:Class 1, Division 1, Groups C, D, E, F, and G
Enclosure:Aluminum, NEMA 4X, 7X
Adjustment:Anywhere within the active level
Span80 to 100% full range
Ambient Temperature:-30° to 160° F
Sensor Material:316 Stainless steel
HART Communication
 Frequency Shift Key
 Multidrop
 Baud Rate1200 bps
 Digital "O" Frequency2200 Hz
 Digital "I"Frequency1200 Hz

3.3 Electric Level Switches (MGS-200EX/MGS-200EX2)

3.3.1 INTRODUCTION

The MGS-200EX and MGS-200EX2 are hermetically sealed, bistable-latching switches designed for magnetic MagGage™ series gages only. The MGS-200EX has single pole double throw contacts (SPDT) and the MGS-200EX2 has double pole, double throw contacts (DPDT). The switch will change state when the float passes by it in a rising or falling level condition. The switch remains in a latched position until the float passes the switch in the opposite direction.

3.3.2 MGS-200EX/EX2 SPECIFICATIONS

Maximum switching voltage:	150 VDC/VAC
Maximum switching current amps:	1.0 amps (VDC/VAC)
Maximum switching wattage:	25 watts (VDC/VAC)
Minimum breakdown volts:	250 VDC
Maximum Temperature (standard):	350° F
Maximum Temperature (HT option)	650° F
Dead Band:	0.35 inch

3.3.3 MOUNTING

The MGS200EX/EX2 is mounted to the MagGage chamber with all 316 Stainless Steel worm gear pipe clamps. Rod-mounted switch assemblies are available as a factory installed option. Switch points can be changed at any time by loosening the clamps and sliding the switch vertically to the desired set point.

3.3.4 OPERATION

When the switch is first installed, it is necessary to set the switch for normal operation. This is accomplished by passing the float past the switch. The chamber can be filled with liquid so the float will pass the highest switch, and then be drained, or by manually sliding the switch past the float in both directions. If the switch is being positioned above the float, the float must pass in the down direction before installation and conversely, if the switch is positioned below the float, the float must pass in the up direction before installation.

3.3.5 ELECTRICAL WIRING - RISING LEVEL

N/O	Red	Terminal 1	Closes on rising level.
C	Green	Terminal N	
N/C	Blue	Terminal 2	Opens on rising level.

3.3.6 ELECTRICAL WIRING - FALLING LEVEL

N/C	Red	Terminal 1	Opens on falling level.
C	Green	Terminal N	
N/O	Blue	Terminal 2	Closes on falling level.

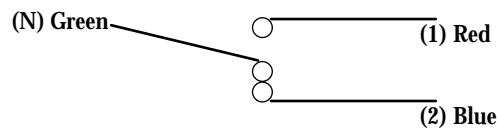

3.4 Electric Level Switches (MGS-500EX/MGS-500EX2)

3.4.1 INTRODUCTION

The MGS-500EX and MGS-500EX2 are hermetically sealed, bistable-latching switches designed for magnetic MagGage series gages only. The MGS-500EX has single pole double throw contacts (SPDT) and the MGS-500EX2 has double pole, double throw contacts (DPDT). The switch will change state when the float passes by it in a rising or falling level condition. The switch remains in a latched position until the float passes the switch in the opposite direction.

3.4.2 MGS-500EX/EX2 SPECIFICATIONS

Maximum switching voltage	500 VDC/VAC
Maximum switching current amps:	3.0 amps (VDC/VAC)
Maximum switching wattage:	100 watts (VDC/VAC)
Minimum breakdown volts:	1000 VDC
Maximum Temperature (standard):	350° F
Maximum Temperature (HT option)	650° F
Dead Band:	0.35 inch

3.4.3 MOUNTING

The MGS500EX/EX2 is mounted to the MagGage chamber with all 316 Stainless Steel worm gear pipe clamps. Rod mounted switch assemblies are available as a factory installed option. Switch points can be changed at any time by loosening the clamps and sliding the switch vertically to the desired set point.

3.4.4 OPERATION

When the switch is first installed, it is necessary to set the switch for normal operation. This is accomplished by passing the float past the switch. The chamber can be filled with liquid so the float will pass the highest switch and then drained, or by manually sliding the switch past the float in both directions. If the switch is being positioned above the float, the float must pass in the down direction before installation and conversely, if the switch is positioned below the float.

3.4.5 ELECTRICAL WIRING - RISING LEVEL

N/O	Red	Terminal 1	Closes on rising level.
C	Green	Terminal N	
N/C	Blue	Terminal 2	Opens on rising level.

3.4.6 ELECTRICAL WIRING - FALLING LEVEL

N/C	Red	Terminal 1	Opens on falling level.
C	Green	Terminal N	
N/O	Blue	Terminal 2	Closes on falling level.

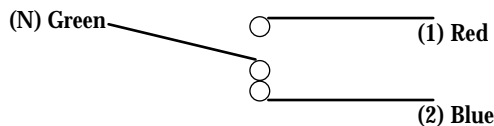

3.5 Electric Level Switches (MGS-700EX/EX2, MGS-900EX/EX2)

3.5.1 INTRODUCTION

The MGS-700/900EX and MGS-700/900EX2 are hermetically sealed bistable-latching switches designed for magnetic MagGage series gages only. The MGS-700/900EX has single pole double throw contacts (SPDT) and the MGS-700/900EX2 has double pole, double throw contacts (DPDT). The switch will change state when the float passes by it in a rising or falling level condition. The switch remains in a latched position until the float passes the switch in the opposite direction.

3.5.2.MGS-700/900 SPECIFICATIONS

	MGS-700EX/EX2	MGS-900EX/EX2
Maximum switching voltage	.250 VAC	.250 VAC
Maximum switching current	.10.0 amps VAC	.15.0 amps VAC
Maximum switching wattage	.2500 watts VAC	.3250 watts VAC
Maximum temperature (standard)	.350° F	.350° F
Maximum temperature (HT option)	.650° F	.650° F
Dead Band	.0.35 inches	.0.35inches

3.5.3 MOUNTING

The MGS-700EX/EX2 and MGS-900EX/EX2 are mounted to the MagGage chamber with all 316 Stainless Steel worm gear pipe clamps. Rod mounted switch assemblies are available as a factory installed option. Switch points can be changed at any time by loosening the clamps and sliding the switch vertically to the desired set point.

3.5.4 OPERATION

When the switch is first installed, it is necessary to set the switch for normal operation. This is accomplished by passing the float past the switch. The chamber can be filled with liquid so the float will pass the highest switch and then drained, or by manually sliding the switch past the float in both directions. If the switch is being positioned above the float, the float must pass in the down direction before installation and conversely if the switch is positioned below the float.

3.5.5 ELECTRICAL WIRING - RISING LEVEL

N/O	Red	Terminal 1(4)	Closes on rising level.
C	Green	Terminal 2(5)	
N/C	Blue	Terminal 3(6)	Opens on rising level.

3.5.6 ELECTRICAL WIRING - FALLING LEVEL

N/C	Red	Terminal 1(4)	Opens on falling level.
C	Green	Terminal 2(5)	
N/O	Blue	Terminal 3(6)	Closes on falling level.

NOTE: Terminal connections for DPDT switches are within the enclosure.

